

My Balsa & Glass Workshop

USAF OA-1K Skyraider II Plans

Updated as of 23 May 2026

This OA-1K Plans file contains all my 2D CAD drawings in PDF format as of the date listed above. If you use the "Back to the Drawing Board" program (<https://drawingboardapp.com/>) as your 2D CAD program, I would be happy to share the .dbfx files used in that program. Also, if you have a 3D printer and would like the STL file for my 3D printed nose cone, just send me an email @: niemanl@balsaandglass.com.

This ZIP file contains the following OA-1K Skyraider II plan PDF files:

- OA-1K_Fuselage_Views_Updated.pdf
- OA-1K_Wings_Plan.pdf
- OA-1K_Stabs_Plus.pdf
- OA-1K_Fuselage_Templates_Updated.pdf
- OA-1K_Nose_Templates_Updated.pdf
- OA-1K_Templates-1_Updated.pdf
- OA-1K_Templates-2.pdf
- OA-1K_Templates-3.pdf
- OA-1K_Templates-4.pdf
- OA-1K_Canopy_Templates.pdf
- OA-1K_Cockpit_Canopy_Views.pdf
- OA-1K_Instrument_Panels.pdf

Don't forget, you can download the latest version of my OA-1K Build Description @: https://balsaandglass.com/images/LarryN/OA-1K/OA-1K_Build_Description.pdf, and view all my build images @: https://balsaandglass.com/Balsa_Photos.html#OA-1K.

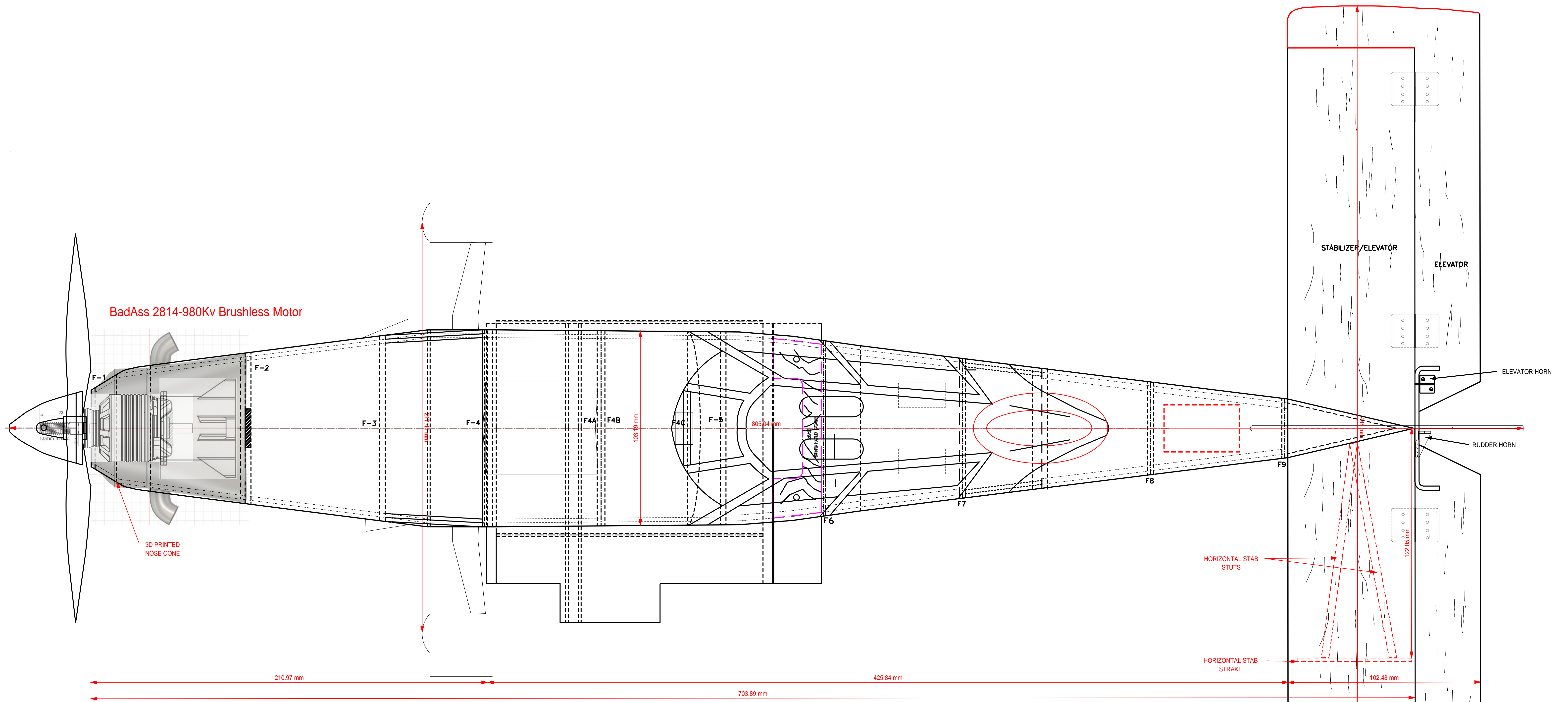

OA-1K Skyraider II Fuselage Top & Side Views

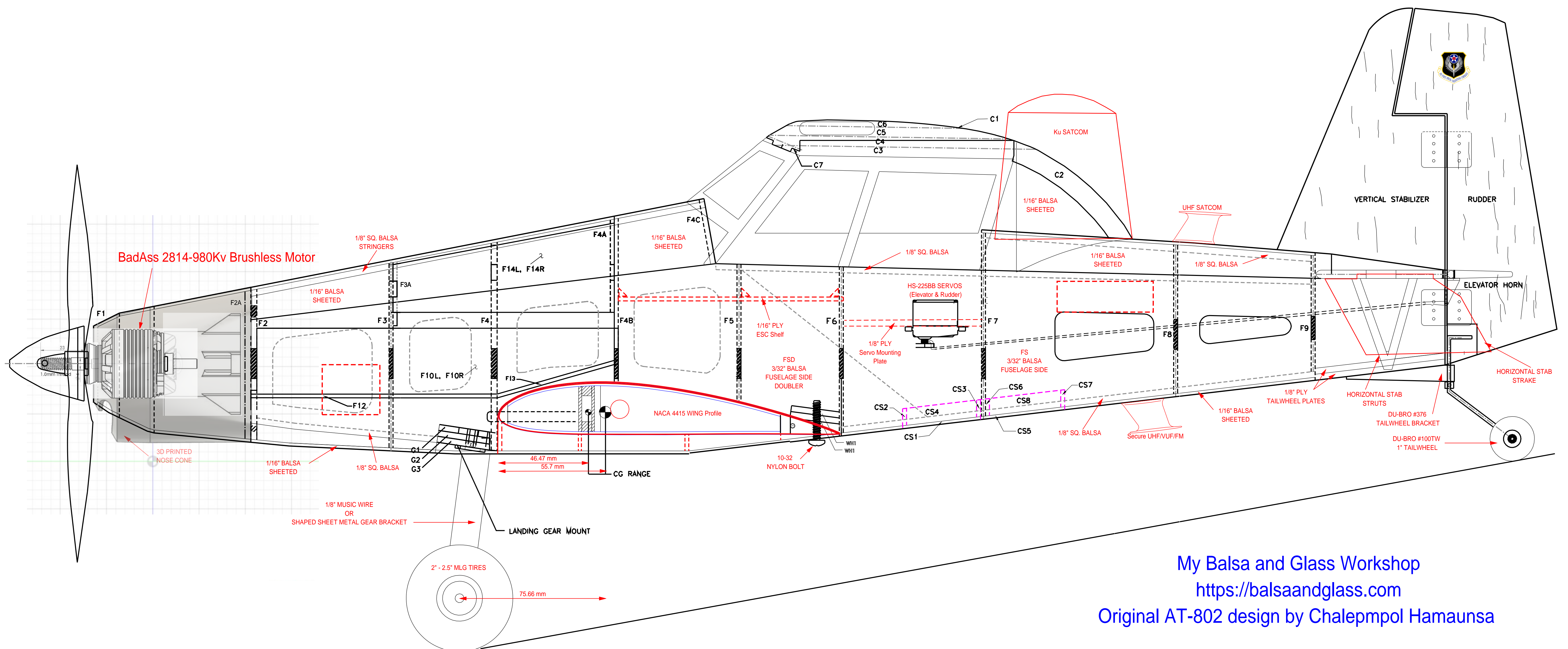

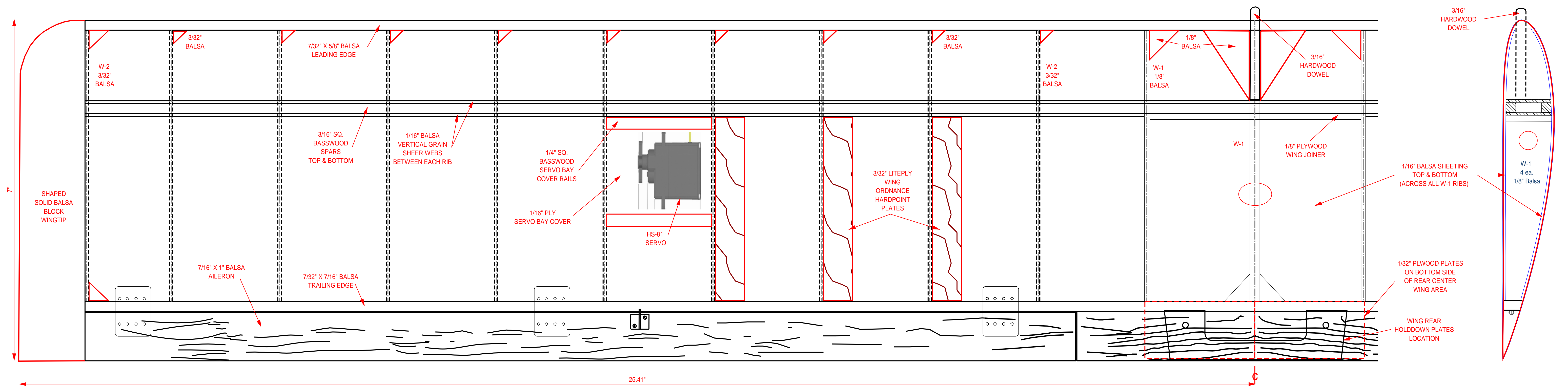

OA-1K Wings

My Balsa and Glass Workshop

<https://balsaandglass.com>

Original AT-802 design by Chalempol Hamaunsa

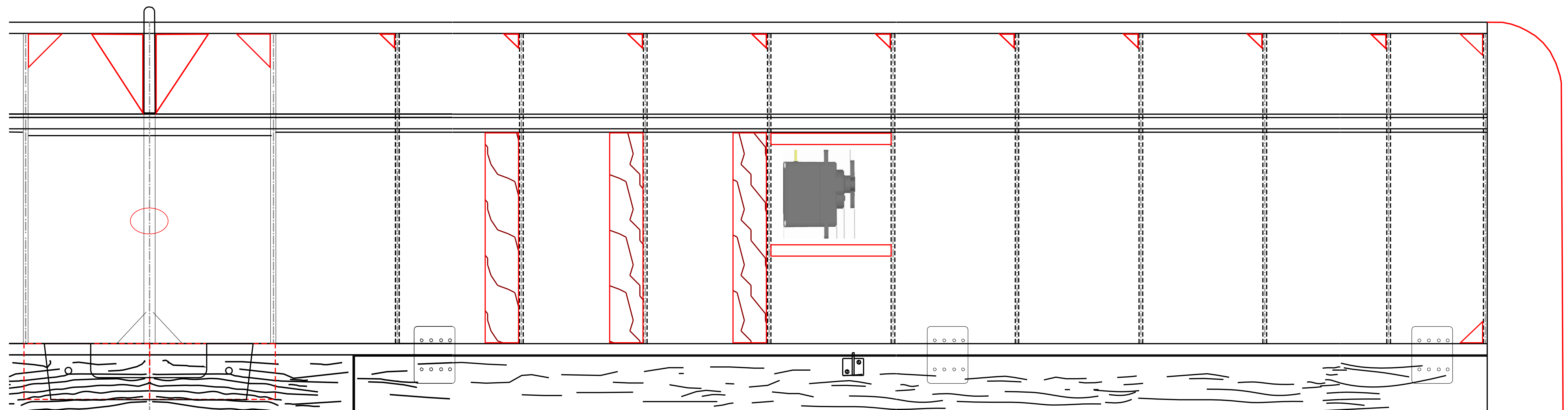

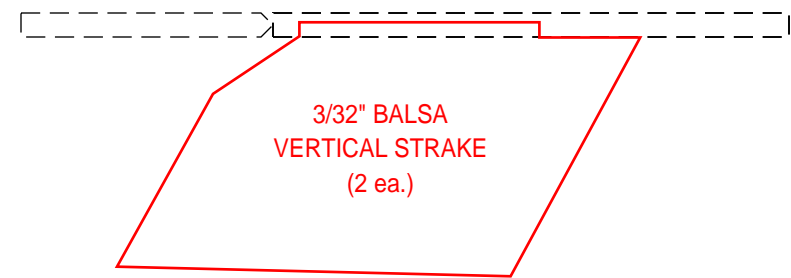
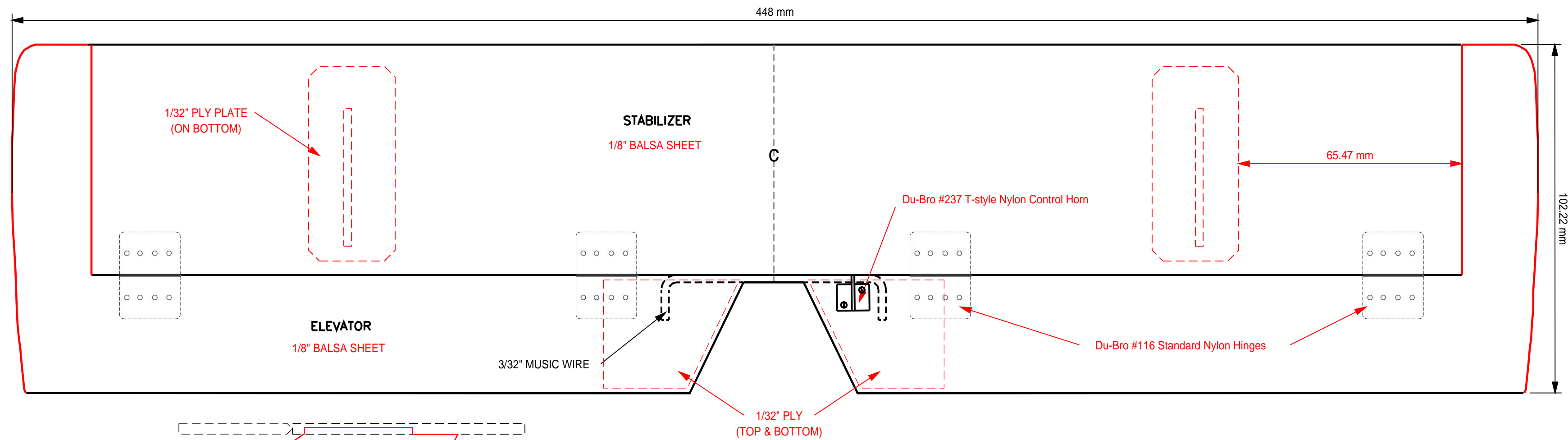

OA-1K HORIZONTAL & VERTICAL STABILIZERS,
ELEVATOR, STRAKES, AND RUDDER

My Balsa and Glass Workshop
<https://balsaandglass.com>

Original AT-802 design by Chalempol Hamaunsa

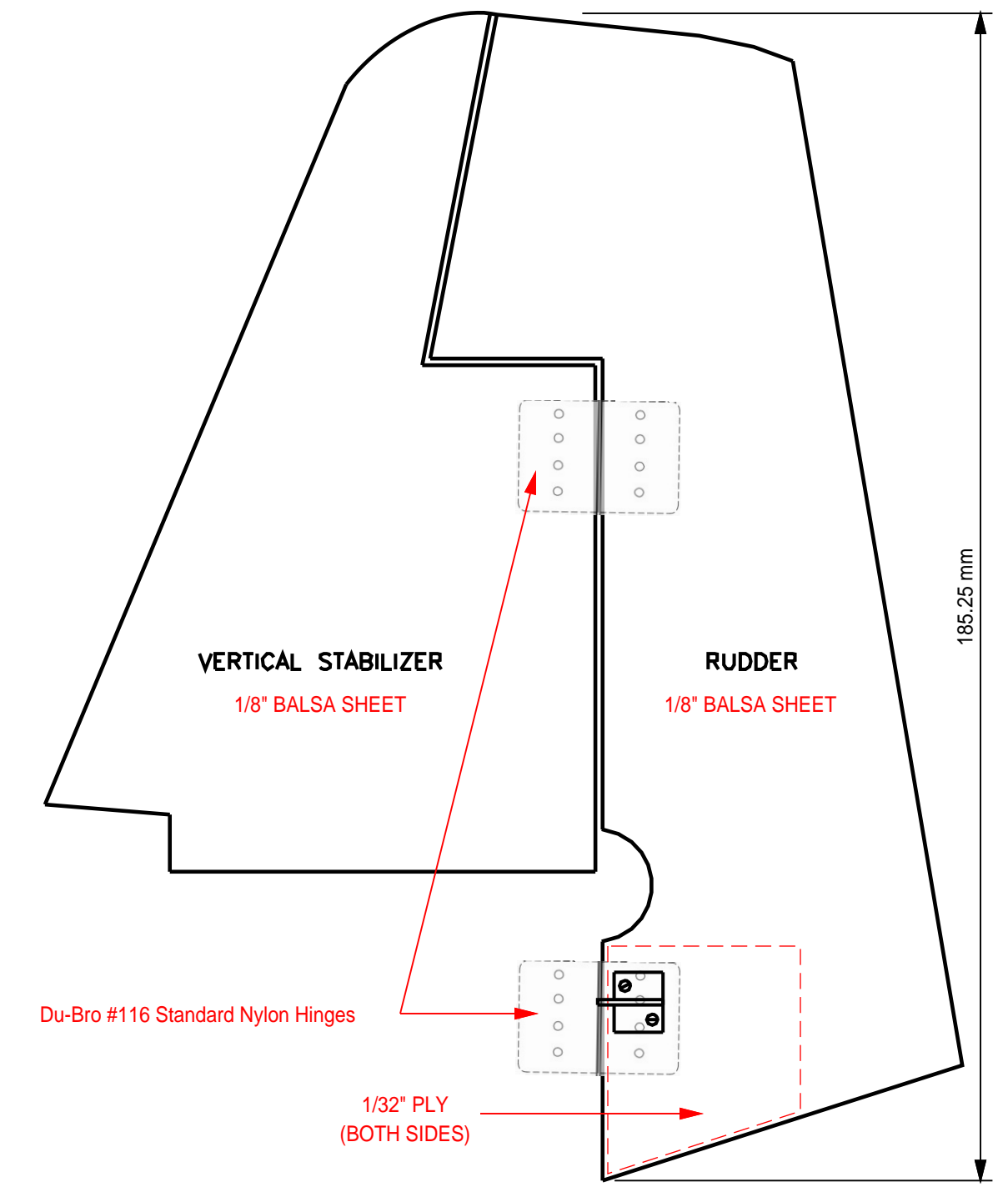

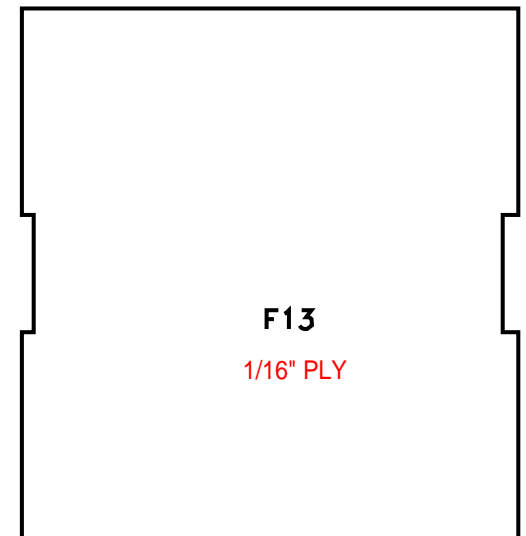
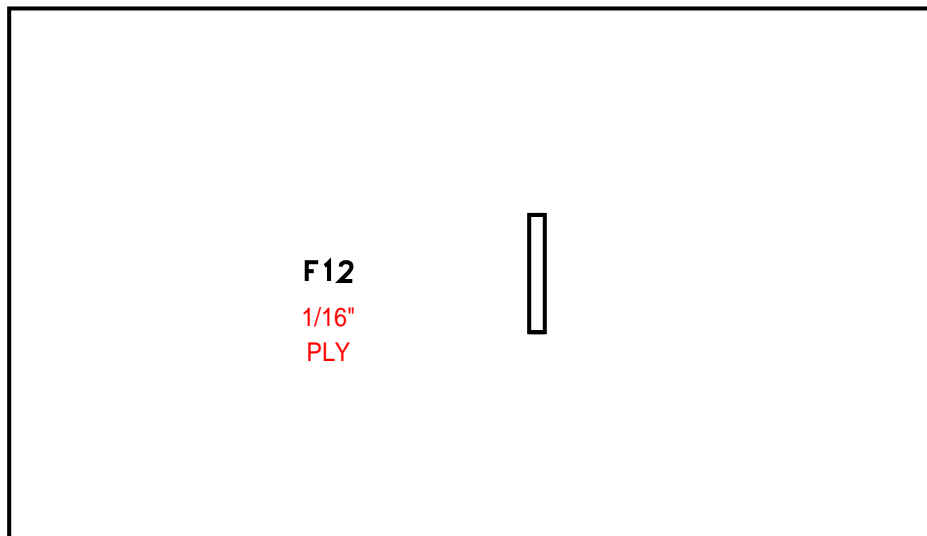
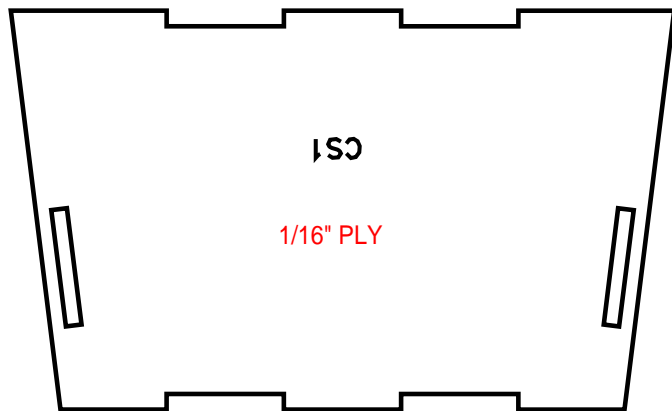
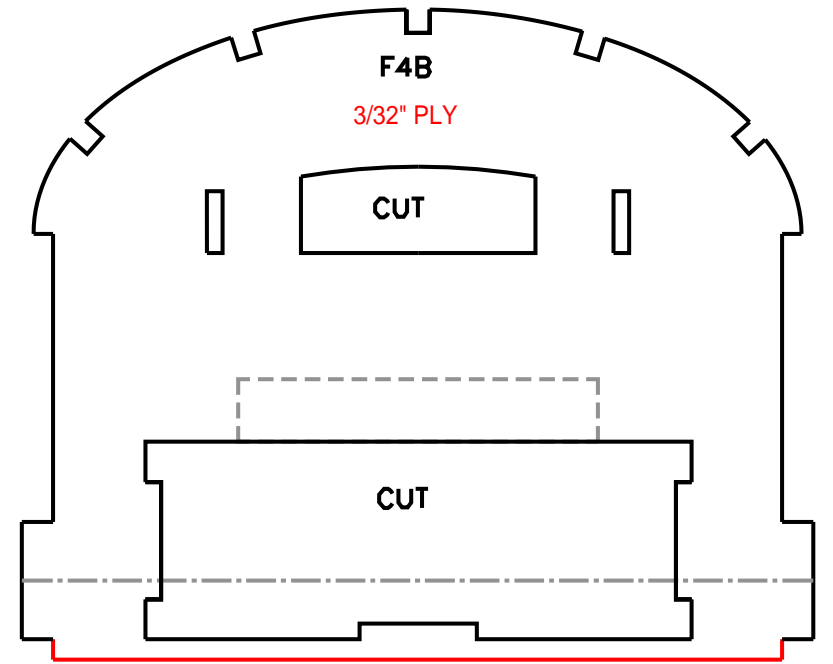
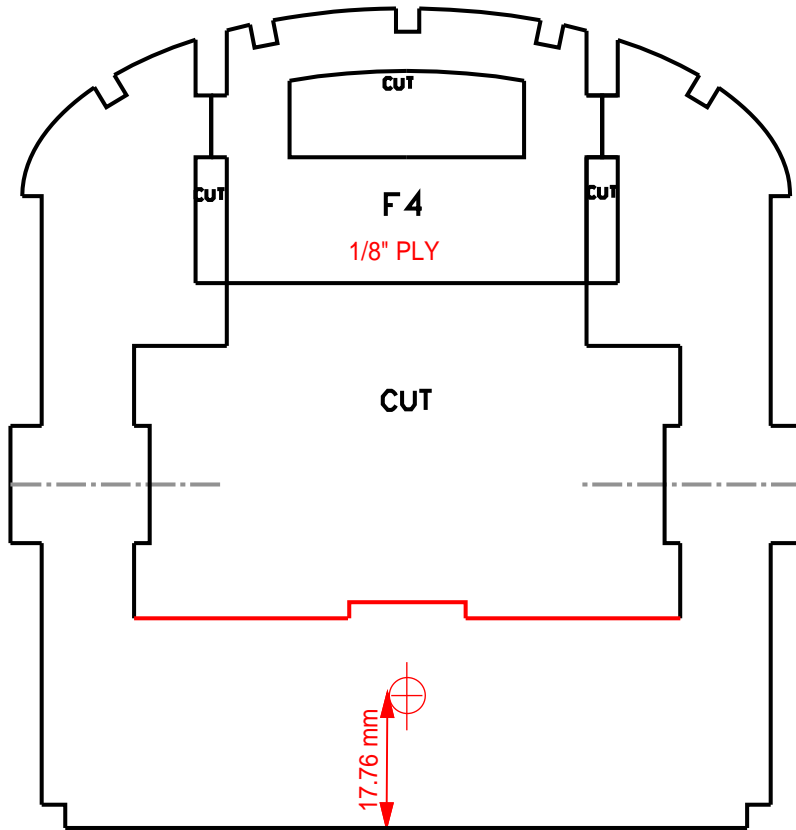
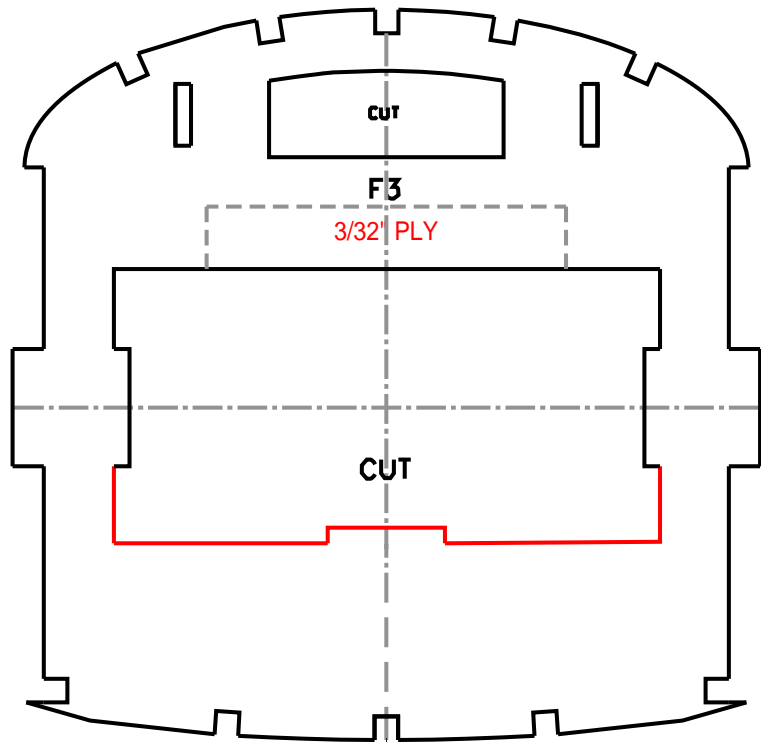

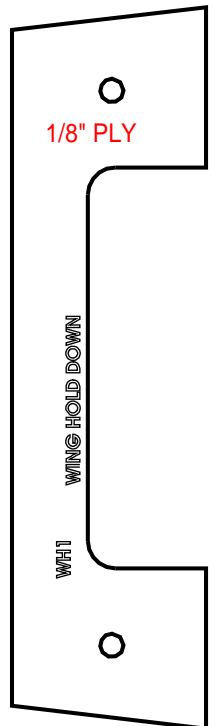
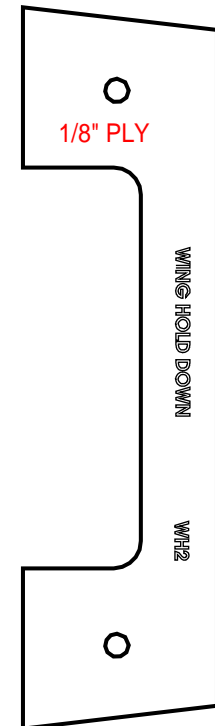
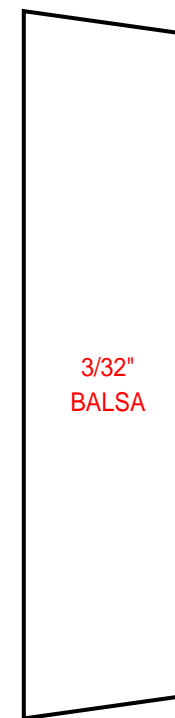
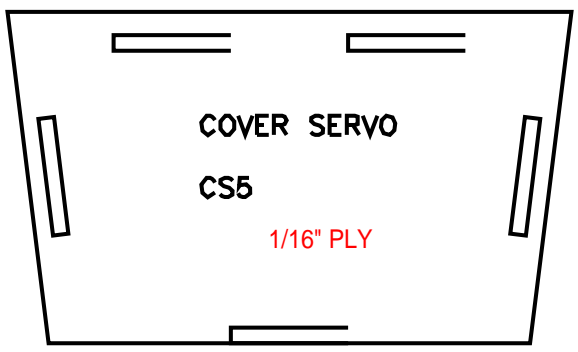
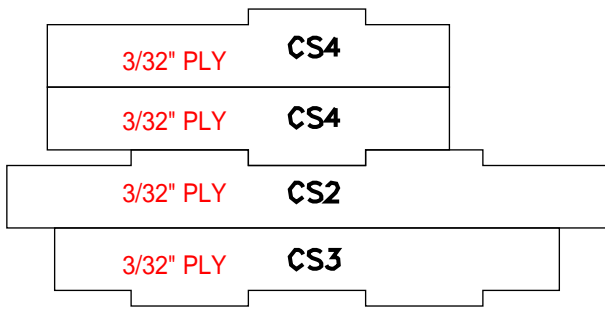
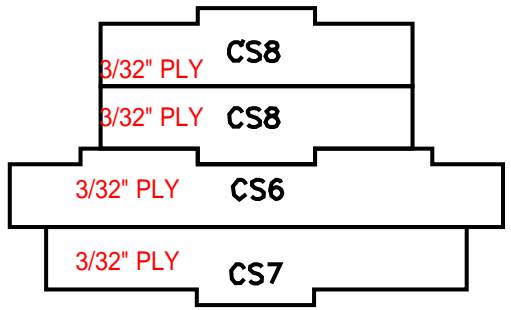
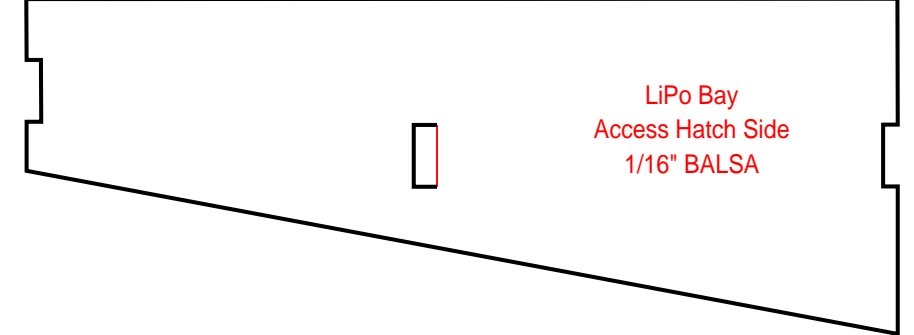
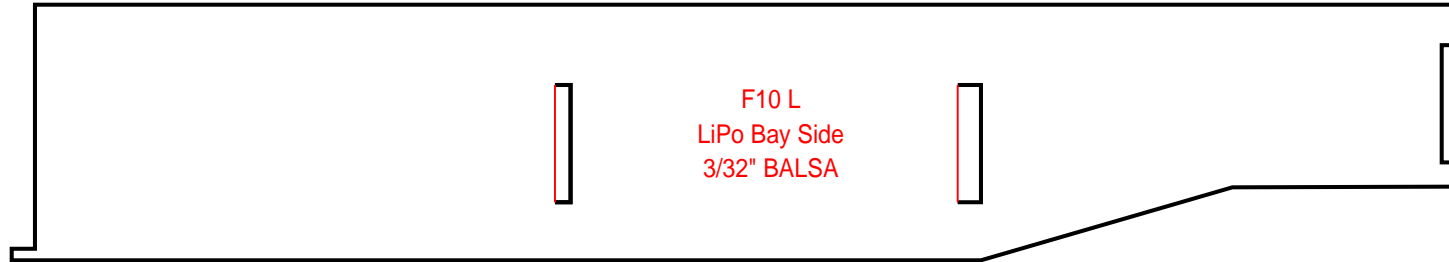
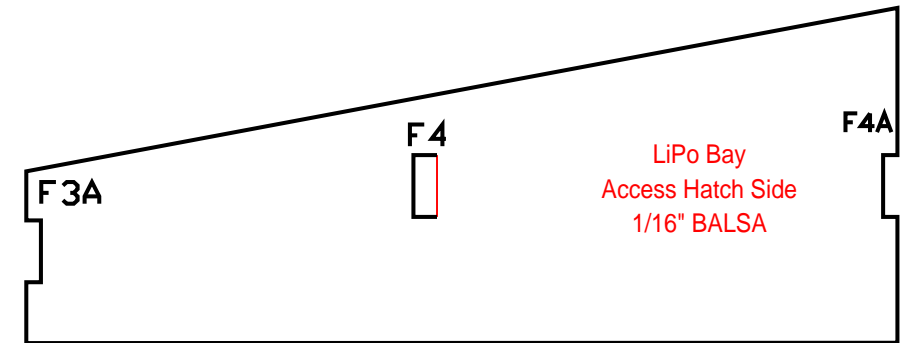
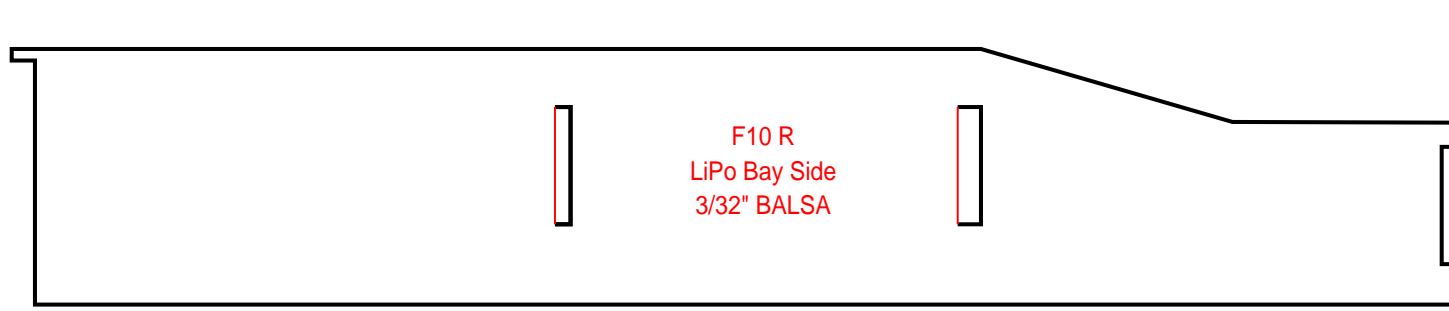

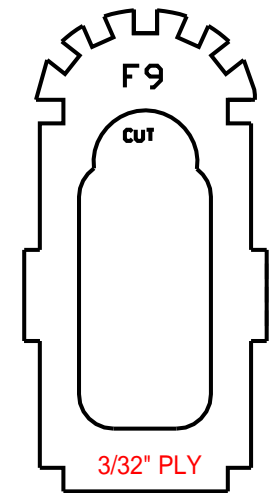
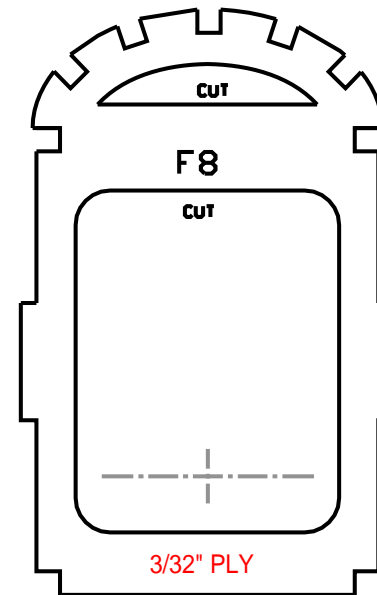
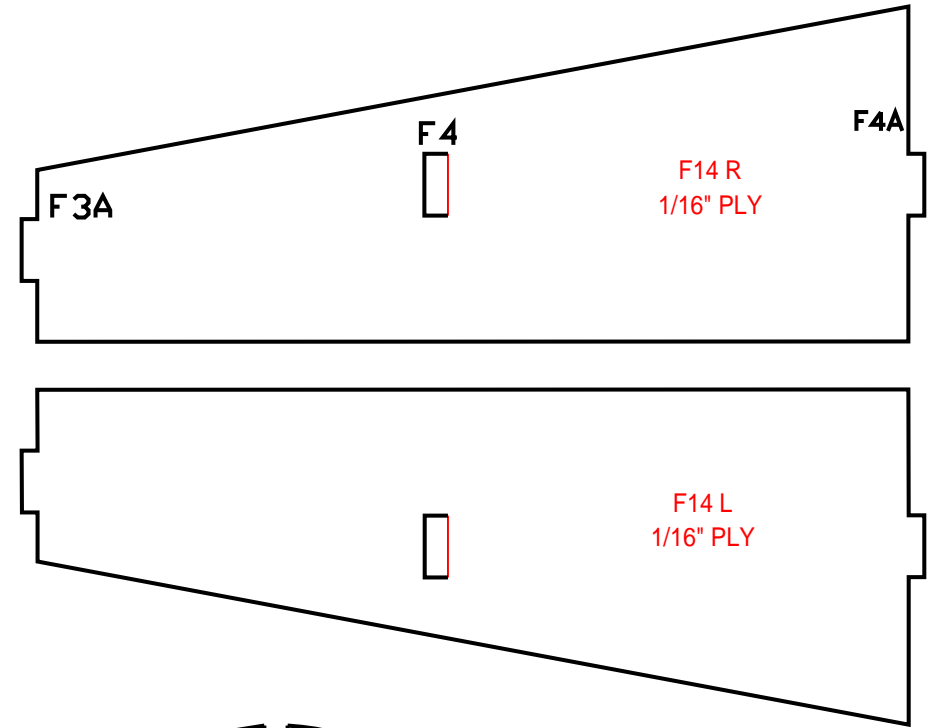
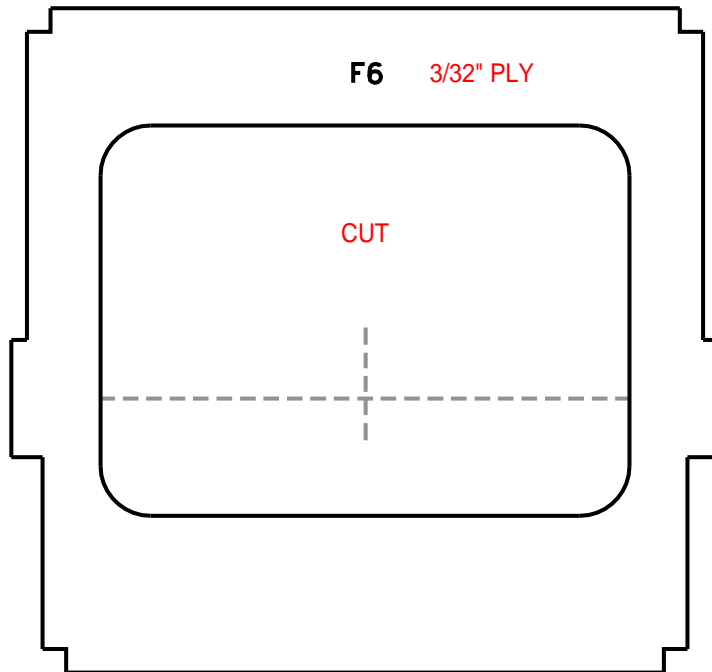
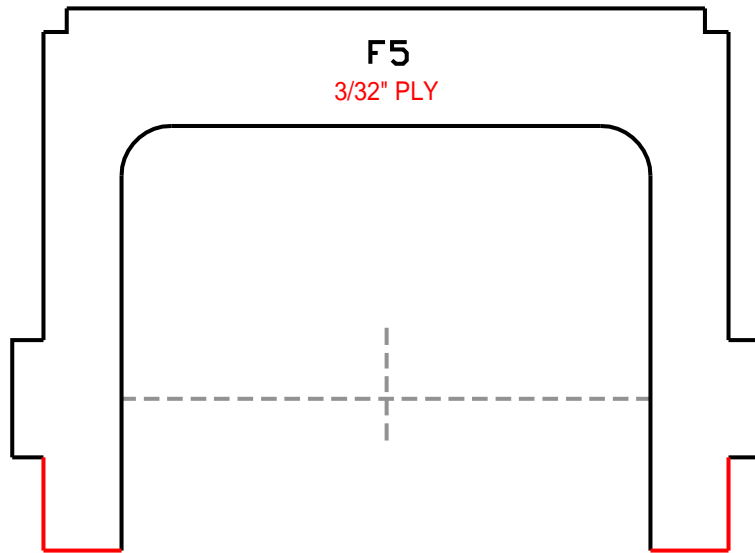
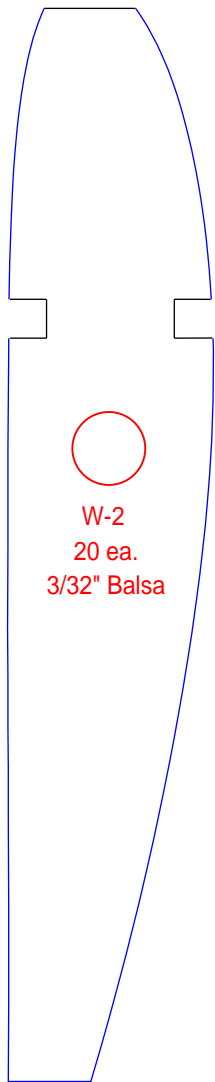
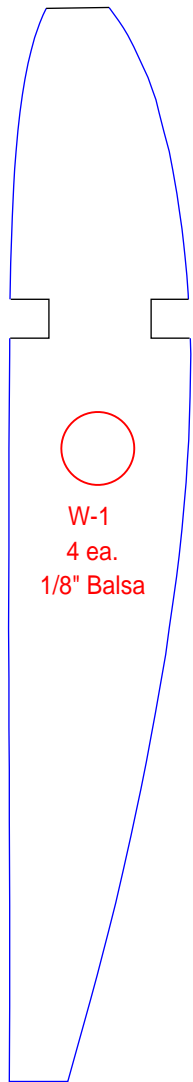

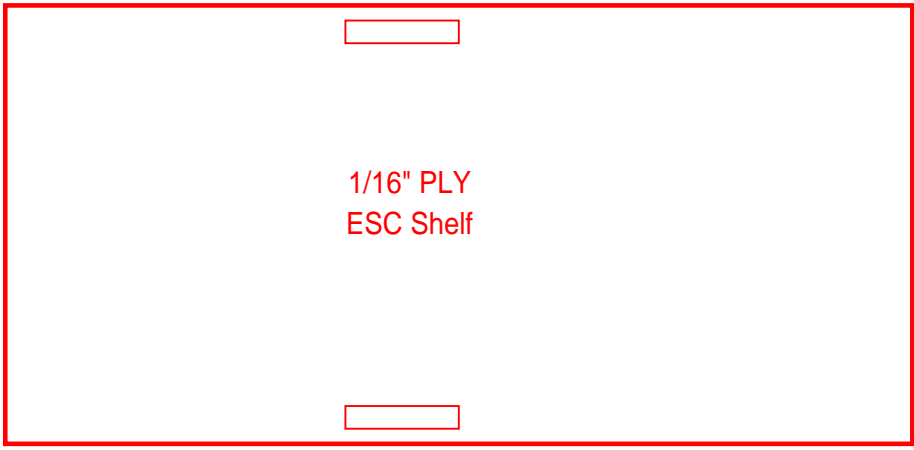
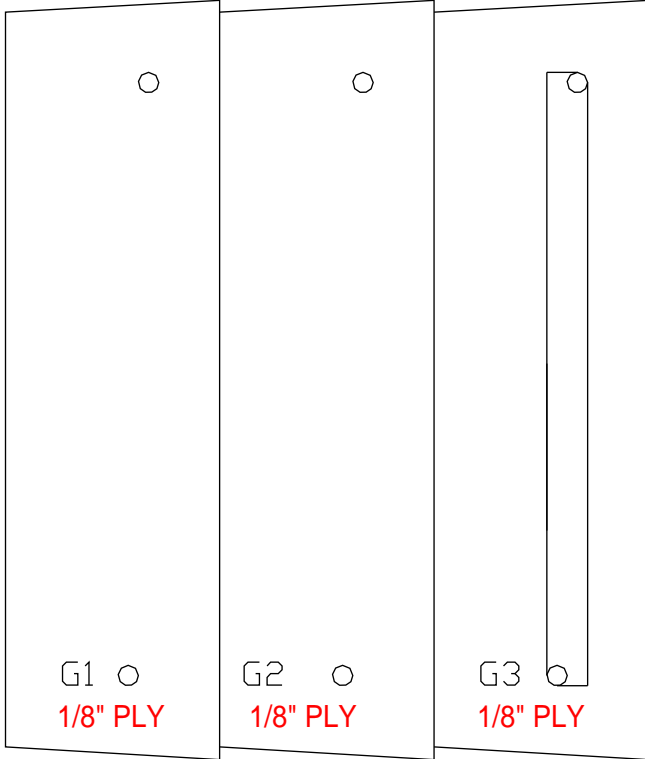
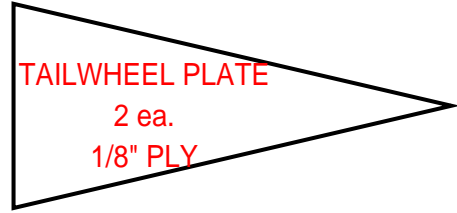
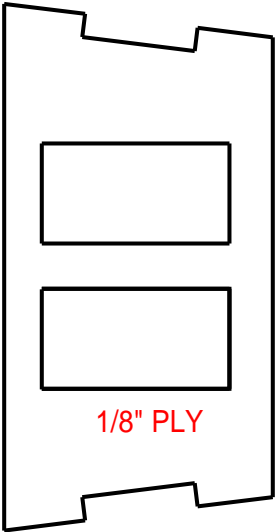
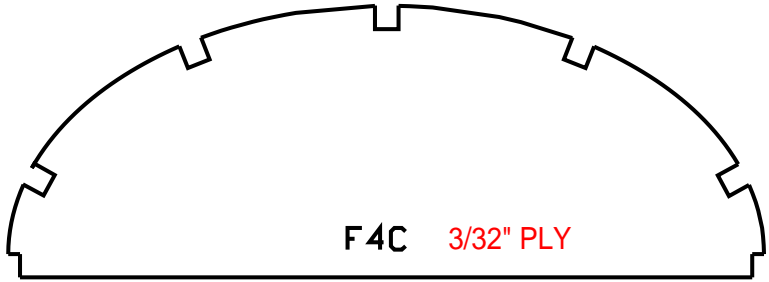
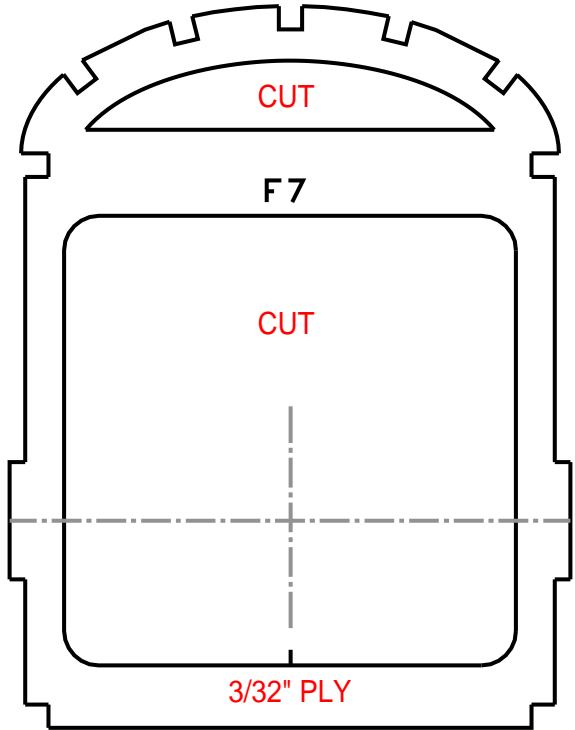
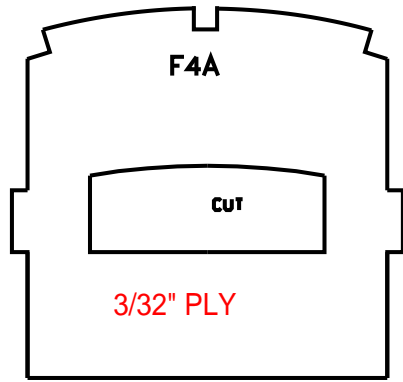
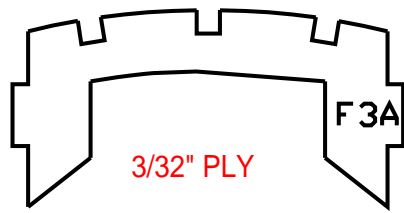

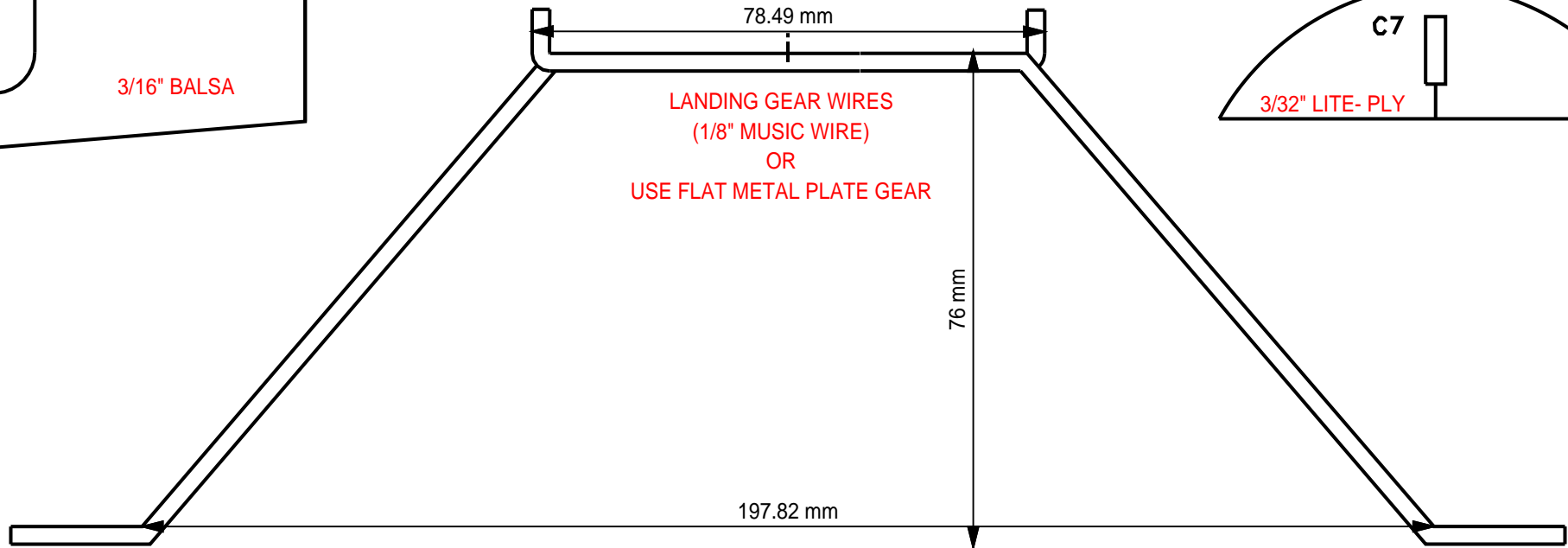
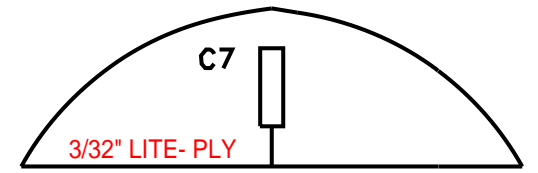
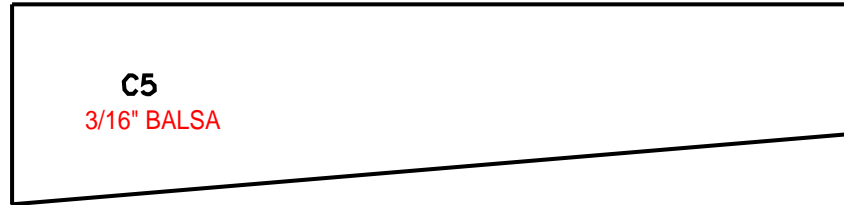
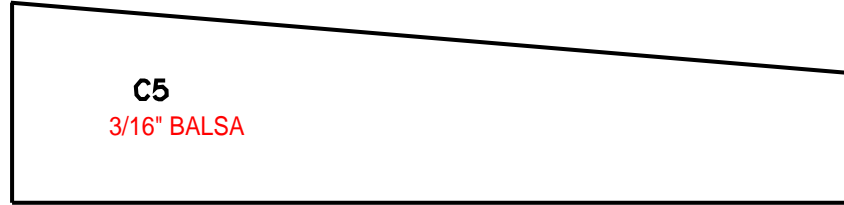
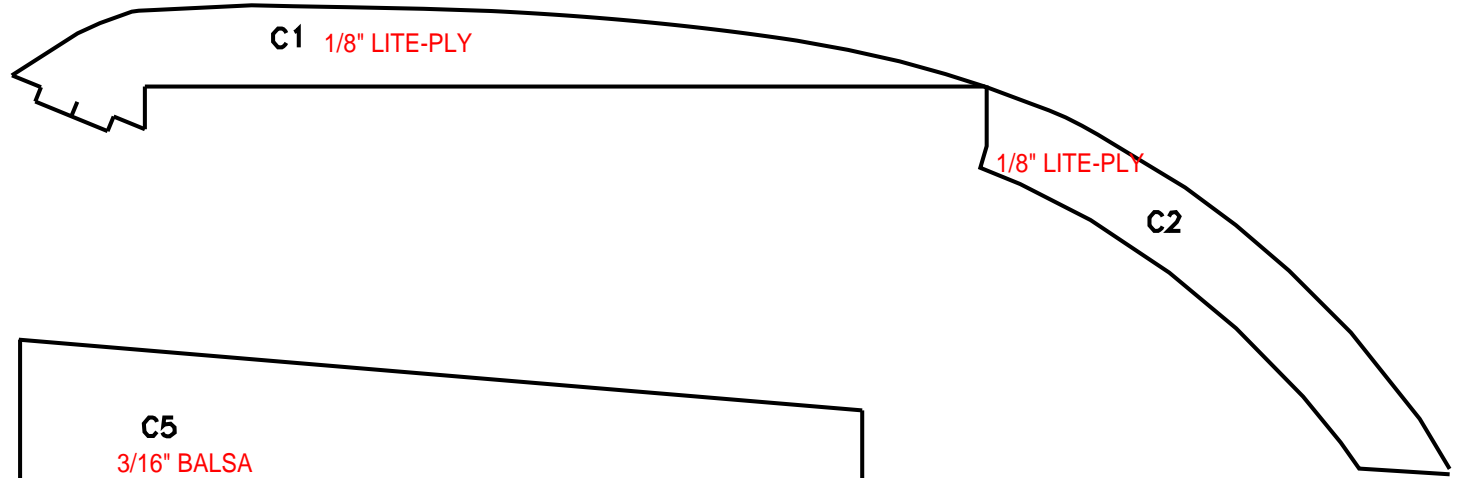
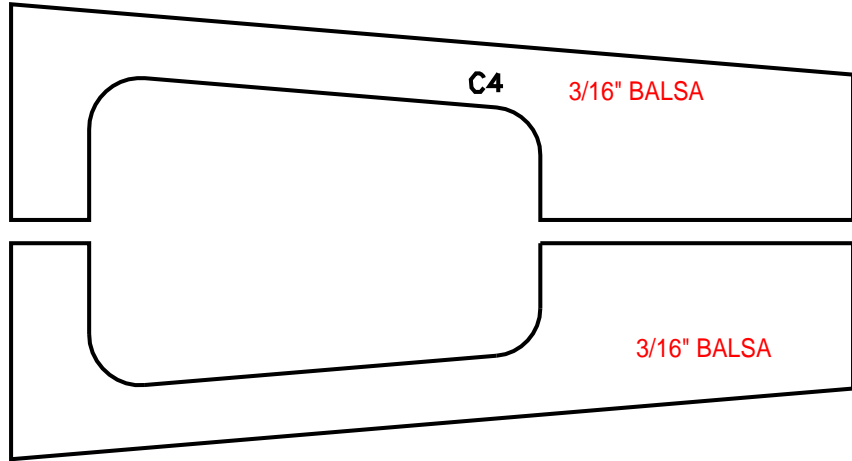
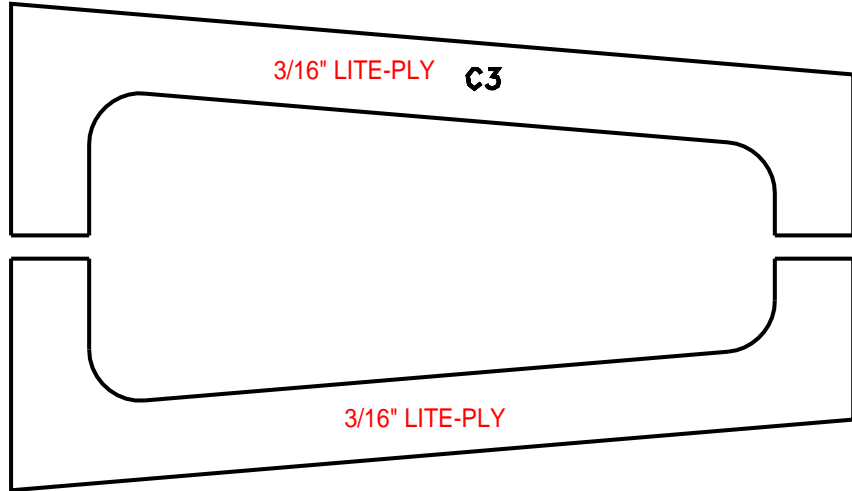

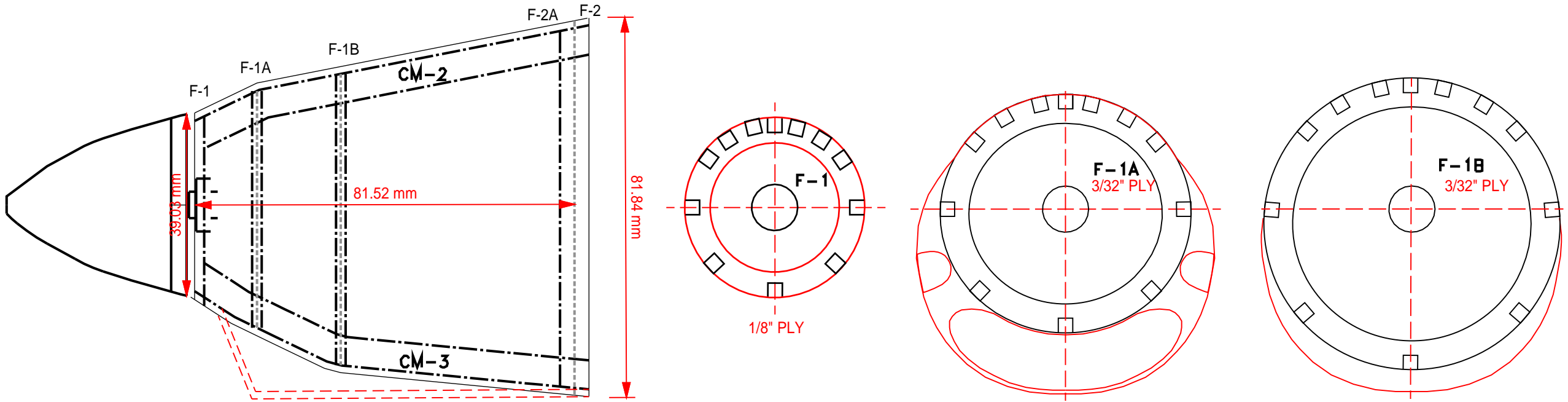

OA-1K Nose Templates

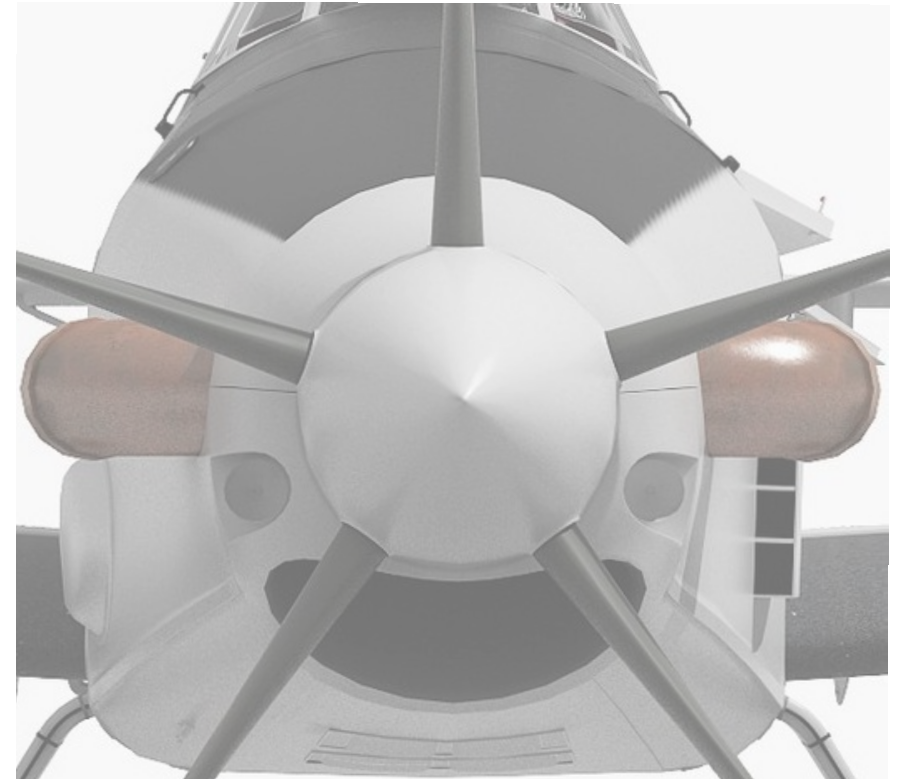
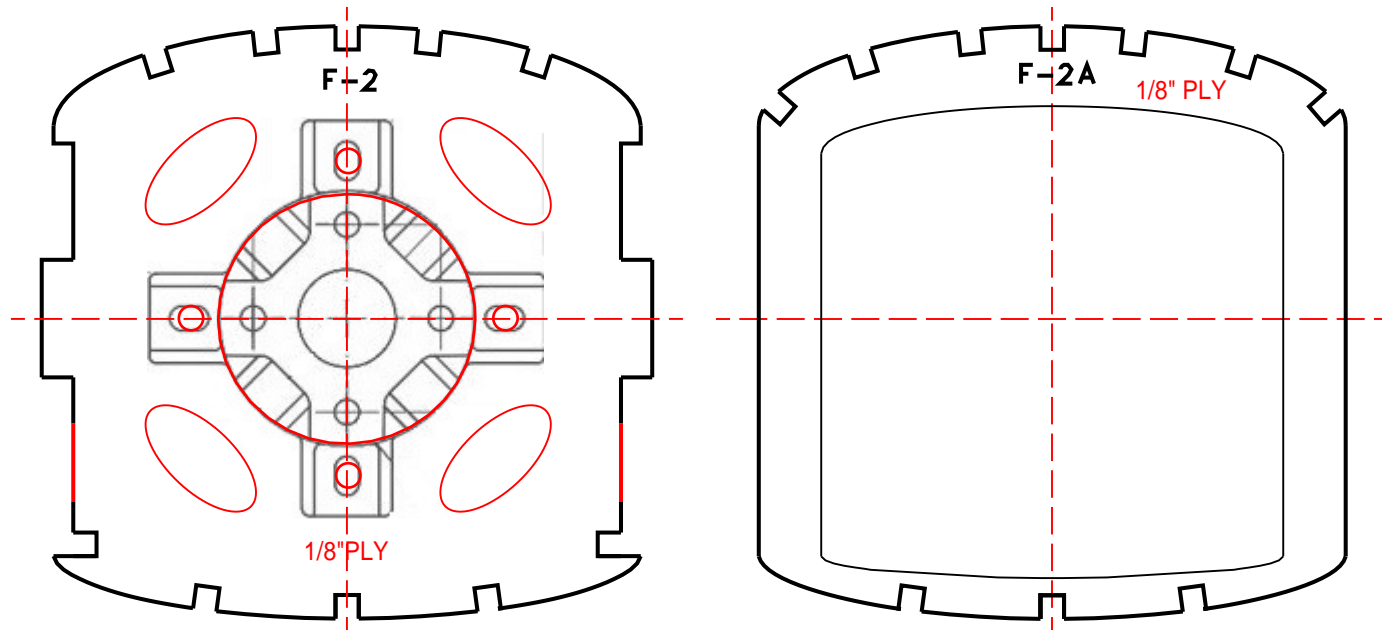

My Balsa and Glass Workshop
<https://balsaandglass.com>

Original AT-802 design by Chalempol Hamaunsa

